



MODEC
QUIETLY CHANGING THE WORLD

ZERO EMISSION VEHICLES

COMMERCIAL RANGE

NO EMISSIONS, NO COMPROMISE

The Modec is the greatest leap forward in the engineering and design of commercial vehicles since the internal combustion engine.

Silent, pollution free and with a carrying capacity to put most other commercial vehicles in the shade, the Modec is the future of urban delivery.

The Modec has been purpose designed and built from the ground up to take full advantage of the very latest technologies.

It's not just an existing vehicle with an electric motor replacing the conventional engine.

A number of strict criteria had to be met, based on range, performance, carrying capacity and driver comfort.

It had to be built tough for the harsh urban environment and, most importantly, it had to be a sound commercial decision and a viable alternative to conventional delivery vehicles. There could be no compromise.

The Modec vehicles you see out on the road today tick all those boxes.

2 TONNE LOAD
50mph (speed limited)
OVER 100 MILE RANGE

A powerful motor, linked to a PRND clutchless transmission and a 10.8 metre kerb-to-kerb turning circle means the Modec thrives in the congested urban environment.

There are also powerful financial arguments for choosing a Modec with:

ZERO CONGESTION CHARGE
ZERO ROAD TAX
ZERO OPERATOR LICENCE

Add to that low servicing and maintenance costs, and you have a package that makes real commercial sense.

By changing the way people look at delivery vehicles, Modec is quietly changing the world.





MODEC AT WORK





BUILT AND DESIGNED FOR THE REAL WORLD

Designed and built from the ground up, the Modec has been created with one purpose in mind: To provide a zero emission vehicle that is a sound commercial decision.

ZERO EMISSION

Because it's not a hybrid, the Modec, when recharged using energy from a renewable source, produces no emissions at all. Zip, zero... not a thing.

SILENT RUNNING

Noise pollution from traffic is a major problem in residential and retail areas. The Modec is whisper quiet, making it ideal for early morning or late night deliveries.

TIGHT TURNING

With a turning circle of just 10.8 metres and high visibility driving position, the Modec is easy to manoeuvre and park in today's congested urban environments.

iBUTTON ENTRY/START

The iButton security entry/start system not only opens the door, but it also prevents the vehicle from being started or moved if the driver is not sitting in the driver's seat.

BOUNCE-BACK PANELS

No one's perfect, so if a driver does happen to hit a bollard or other object, the lower body panels resume their original shape with little or no damage.

THE COMFORT ZONE

Driver fatigue is one of the most common causes of accidents, so HGV standard seats and advanced ergonomics deliver the ultimate driving environment.

HIGHWAY TO DOORWAY

Being exhaust-free and quiet, a Modec can take a delivery right to the door, even in malls or shopping centres and it won't leave any nasty oil stains behind.

WALK-IN, WALK-OUT

With full standing room and its walk-in, walk-out configuration, the driver has easy access to the load and can always get out on the safest side of the vehicle.

24/7 OPERATION

A Modec can recharge overnight in just 8 hours, or the battery can be exchanged for a fully charged unit in just 20 minutes for true 24/7 operation.

OUR BATTERY, OUR RESPONSIBILITY

You own the vehicle, but lease the battery. This means that when it comes to battery maintenance, or when it's time to dispose of the battery, Modec takes care of everything.

100,000 MILE/3 YEAR WARRANTY

Every Modec has a 100,000 mile, 3 year warranty, backed up by a comprehensive parts and servicing network including a nationwide breakdown service.

BE SEEN TO BE GREEN

These days consumers are choosing companies with good environmental credentials, so a Modec is an eye catching billboard advertising your commitment to the environment.

FUTURE PROOF

The Modec has been designed to take advantage of new technology as it becomes available, so batteries can be easily upgraded and fitted to new or existing vehicles.

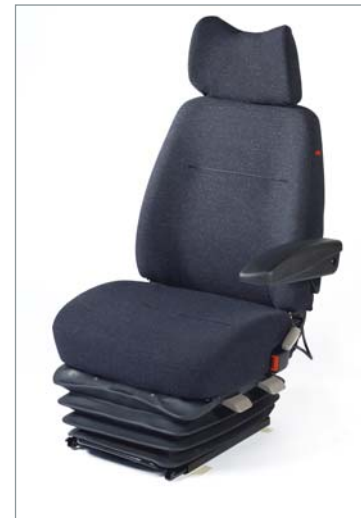

Advanced ergonomics and HGV standard seats make the Modec as comfortable as it is easy to drive.

Comfort and safety is enhanced with a list of standard features that include pull down sunblinds, electric mirrors and windows, power steering and proximity mirrors.

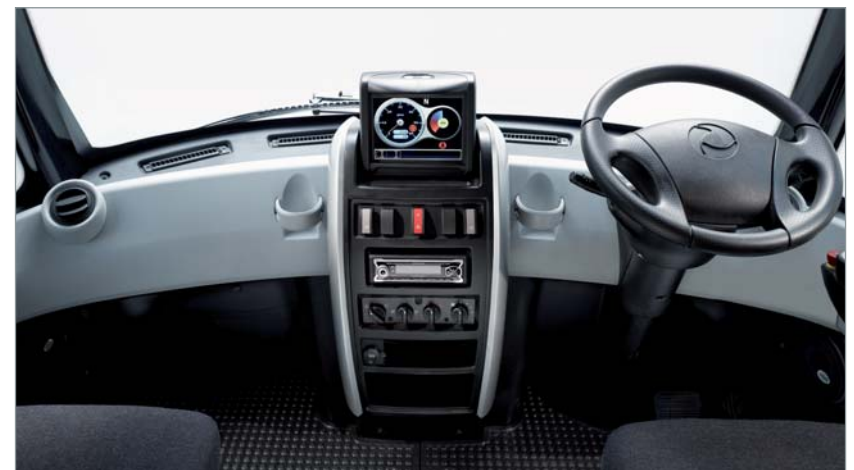



The high strength ladder frame chassis has been purpose designed for the Modec. The battery sits snugly within the frame without taking up valuable cargo space.

For safety it incorporates an energy absorbing frontal structure and is electro deposited for year-round corrosion protection.

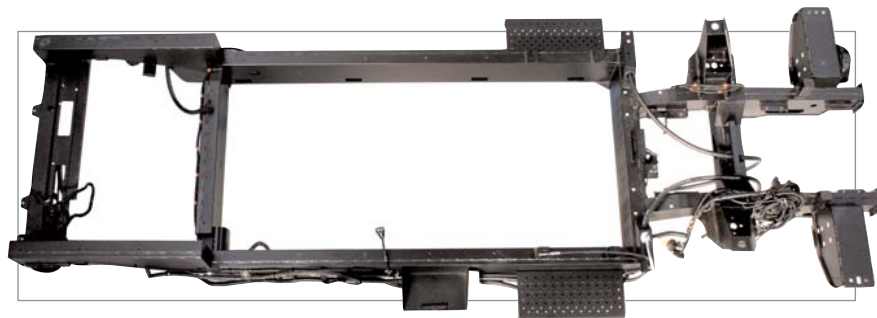

Driving a Modec is simplicity itself. Walk in. Sit down. Select drive. Move off.

There's no noise or vibration to fatigue the driver and when the working day is over just get out, plug in and go home. It's that simple.



Under your right foot there's a massive 300Nm of torque available, with full torque the second you press the accelerator.

PROXIMITY MIRRORS

Internal mirrors allow the driver to spot hazards directly in front of the cab, such as bollards or pedestrians.

HIGH VISIBILITY

Large glass area and command driving position offers maximum visibility.

CUSTOM SEATING

HGV standard seats, customised to Modec specifications, provide all-day driver comfort.

STRIKING DESIGN

A triumph of form and function, the Modec's eye-catching design attracts attention wherever it goes, so more people will associate your logo and company with excellent green credentials.

BOUNCE-BACK PANELS

Energy absorbing body panels return to their previous shape after an impact.

REGENERATIVE BRAKING

Extends range by returning power to the battery when braking or decelerating.

WALK-IN CAB

Rear cab door allows the driver to exit vehicle from whichever side is safest.

iBUTTON ENTRY/START

Keeps vehicle secure and prevents the vehicle moving unless the driver is seated.

98% RECYCLABLE

Even at the end of its life, 98% of a Modec is still quietly changing the world.

10.8M TURNING CIRCLE

Tight, congested urban streets are where the Modec runs circles around the competition.

ABS ("Anti-lock Braking System") & EBD ("Electronic Braking Distribution")

Keeps the driver in control, even on poor roads or during adverse weather conditions.



EVERYTHING YOU NEED- NOTHING YOU DON'T

Think of the Modec as a blank canvas, ready to be customised or modified. The Modec can be supplied as a van, drop side or bare chassis. The high strength steel ladder chassis can handle just about anything you want to mount on it, from refrigerated boxes to tail lifts. Contact the Modec sales team to discuss your particular business requirements.

POWERFUL MOTOR

With 102hp and 300Nm of torque, the Modec has the power to get the job done.

HIGH-STRENGTH CHASSIS

The steel ladder-frame chassis is electro-deposited for all-year corrosion protection.

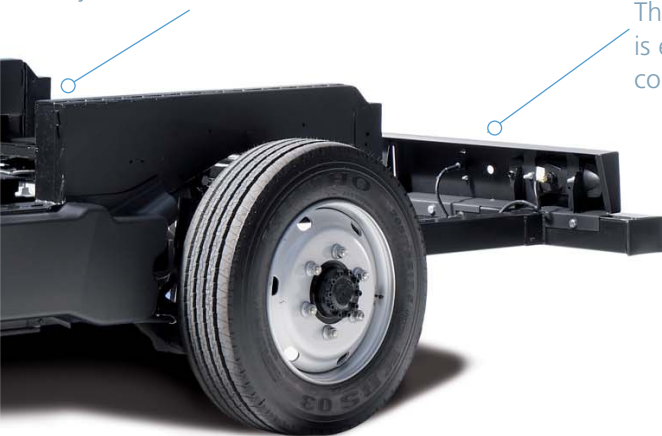

MODEC CHASSIS CAB



MODEC BOX VAN



MODEC DROPSIDE

EQUIPMENT AND SPECIFICATION

MOTOR

Maximum power	102hp
Maximum torque	300Nm
CO ₂ emissions	Zero g/km

TRANSMISSION

PRND (Park, Reverse, Neutral, Drive) clutchless transmission

BRAKING SYSTEM

Front	4 Piston Calipers
Rear	254mm Duo Servo Drum
ABS (Anti-lock Braking System)	Standard
EBD (Electronic Braking Distribution)	Standard
Regenerative braking	Standard

WHEELS AND TYRES

Wheels	17.5x6 Steel
Tyres	205/75 R 17.5 10PR (Regroovable)

PERFORMANCE

Maximum speed (speed limited)	50 mph
-------------------------------	--------

CAPACITY

Cargo capacity	2 Tonnes
----------------	----------

WEIGHTS

Kerb weight	3000kg
Gross vehicle weight	5490kg
Maximum body/payload	2500kg

STEERING

Electro-hydraulic power assisted	Standard
Turning circle (kerb-to-kerb)	10.8m
Steering wheel turns lock-to-lock	4.6

SUSPENSION

Front: Independent with roll control and anti-dive
Rear: Beam drive axle with trailing arms and Panhard rod
Coil spring or air option available

OTHER STANDARD FEATURES

- Electric windows
- Electric mirrors
- I-Pack driver information display

OPTIONS

- Tilt sunroof
- Battery options available
- Left hand drive

CHARGING PROCEDURE



GET OUT...



PLUG IN...



GO HOME.

Yes, it's really that simple, all you need is a 3-phase supply back at base.

YOU CAN CHOOSE ANY COLOUR YOU LIKE AND IT WILL STILL BE GREEN

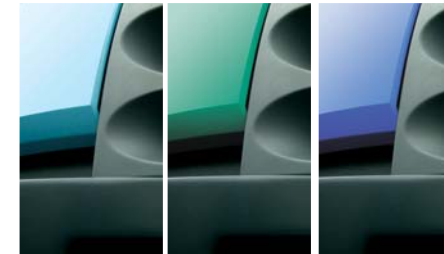

PERSONALISED LIVERY AVAILABLE ON REQUEST



While every effort has been made to ensure the contents of this brochure are accurate at the time of printing and in line with our policy of continuous product development and improvement, Modec Limited reserves the right to change specifications and make any modifications to the range of Modec vehicles at any time. All rights reserved. No part of this brochure may be reproduced in any form without prior written permission from Modec Limited.

This brochure has been written, designed and produced by nbcreative. www.nbcreative.com

STAYING GREEN

This brochure is printed on Era Silk paper, produced from 50% FSC certified de-inked post consumer waste fibre and 50% FSC certified virgin fibre pulp. The laminate is CelloGreen® conforming to DIN EN 13432:2000-12 for compostability and biodegradation.

Printing is by Taylor Bloxham, an environmentally responsible printer with a history of introducing 'green' working practices to the printing process. They have ISO14001 and FSC Chain of Custody SA-CoC-1487 certification. The paper is supplied by The James McNaughton Group, who are ISO14001 and FSC certified and use a Modec for deliveries.

FSC – BECAUSE FORESTS MATTER

The Forest Stewardship Council - FSC, is an international organisation that promotes the responsible management of the world's forest. Certification involves inspection and auditing of the land and tracking the timber through the production process until it reaches the end user.



If you have finished with this brochure, please pass it on to someone else who may be interested or have it recycled.





Contact the Modec team to see how you could help quietly change the world on +44 (0)870 626 0011 or info@modecZEV.com



MODEC
QUIETLY CHANGING THE WORLD

MODEC LIMITED
Progress Way,
Binley Industrial Estate,
Coventry, CV3 2NT

Tel: +44 (0)870 626 0011
Email: info@modeczEV.com
Web: www.modeczEV.com